

**Characteristics**

Pilot operated pressure reducing valves for in-line mounting series R4R have a similar design to the subplate mounted R4R series. For single functions – where no manifold blocks are used – the valves can be directly placed in the pipework.

The valves are available with 2 ports (L-body) or with 3 ports (T-body).

**Features**

- Pilot operated with manual adjustment
- Normally closed to avoid undesired motion
- 2 interfaces
  - L-body (R4R06-G $\frac{3}{4}$ ", R4R10-G1 $\frac{1}{4}$ " )
  - T-body (R4R03-G $\frac{1}{2}$ ", R4R06-G1" )
- 3 pressure stages
- 3 adjustment modes
  - Hand knob
  - Acorn nut with lead seal
  - Cylinder lock
- With optional vent function



R4R10 L-body

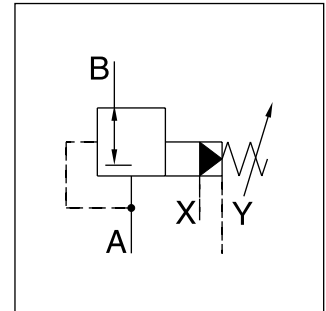

**R4R06 L-body**

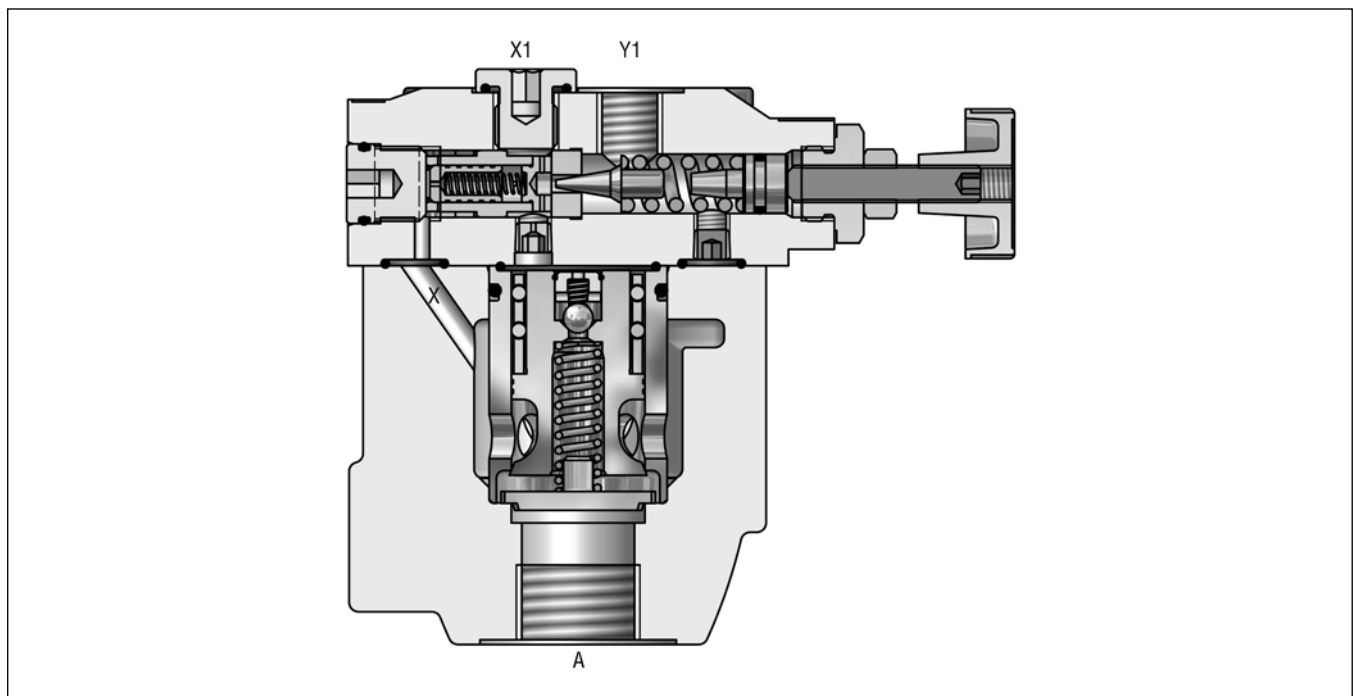

**Ordering Code**

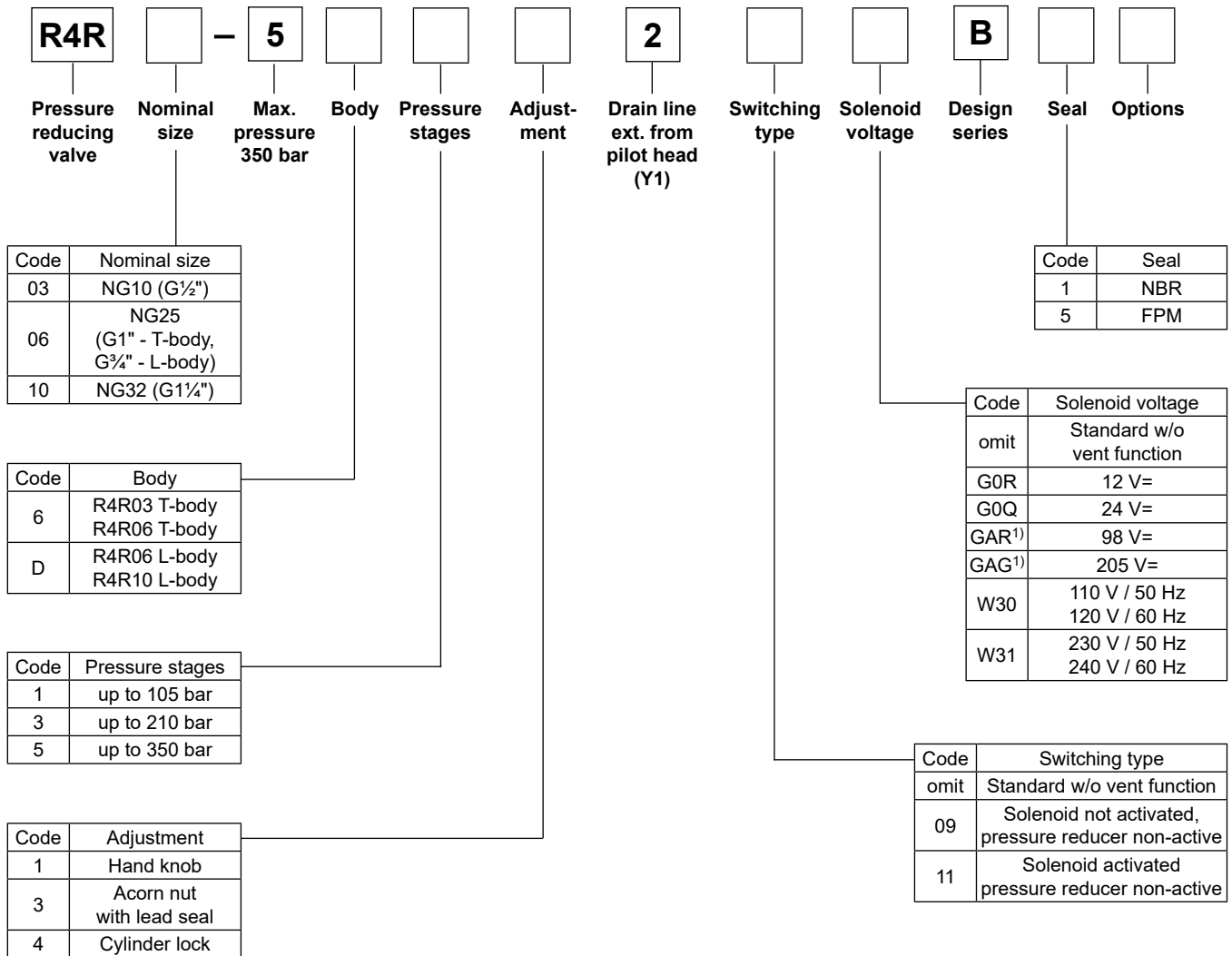

<sup>1)</sup> To be used in combination with rectifier plugs at 120 VAC / 230 VAC power supply.

**R4R**

General				
Design	T-body		L-body	
Size	03 (1/2")	06 (1")	06 (3/4")	10 (1 1/4")
Mounting	Threaded body			
Mounting position	unrestricted			
Ambient temperature [°C]	-20...+60			
MTTF <sub>D</sub> value [years]	75			
Weight [kg]	3.2	3.3	5.6	6.6
Hydraulic				
Max. operating pressure [bar]	Ports A, B and X: 350; Port Y depressurized			
Pressure stages [bar]	105, 210, 350			
Nominal flow [l/min]	60	200	200	450
Fluid	Hydraulic oil according to DIN 51524			
Fluid temperature [°C]	-20...+70 (NBR: -25...+70)			
Viscosity permitted [cSt]/[mm <sup>2</sup> /s]	20...400			
Viscosity recommended [cSt]/[mm <sup>2</sup> /s]	30...80			
Filtration	ISO 4406 (1999); 18/16/13			

**R4R with vent function**

General							
Design	T-body			L-body			
Size	03 (1/2")	06 (3/4")	06 (1")	10 (1 1/4")			
Mounting	Threaded body						
Mounting position	unrestricted						
Ambient temperature [°C]	-20...+60						
MTTF <sub>D</sub> value [years]	75						
Weight [kg]	4.9	5.0	7.3	8.3			
Hydraulic							
Max. operating pressure [bar]	Ports A and X up to 350; Ports B and Y depressurized						
Pressure stages [bar]	105, 210, 350						
Nominal flow [l/min]	60	200	200	450			
Fluid	Hydraulic oil according to DIN 51524						
Fluid temperature [°C]	-20...+70 (NBR: -25...+70)						
Viscosity permitted [cSt] / [mm <sup>2</sup> /s]	20...400						
Viscosity recommended [cSt] / [mm <sup>2</sup> /s]	30...80						
Filtration	ISO 4406 (1999); 18/16/13						
Electrical (solenoid)							
Duty ratio	100 % ED; CAUTION: coil temperature up to 150 °C possible						
Protection class	IP65 in accordance with EN 60529 (with correctly mounted plug-in connector)						
	Code	G0R	G0Q	GAR	GAG	W30	W31
Supply voltage [V]		12 V =	24 V =	98 V =	205 V =	110 at 50 Hz 120 at 60 Hz	230 at 50 Hz 240 at 60 Hz
Tolerance supply voltage [%]		±10	±10	±10	±10	±5	±5
Current consumption hold [A]		2.72	1.29	0.33	0.13	0.6 / 0.55	0.3 / 0.27
Current consumption in rush [A]		2.72	1.29	0.33	0.13	2.5 / 2.4	1.25 / 1.2
Power consumption hold [W]		32.7	31	31.9	28.2	70 / 70 VA	70 / 70 VA
Power consumption in rush [W]		32.7	31	31.9	28.2	280 / 290 VA	280 / 290 VA
Solenoid connection	Connector as per EN175301-803, solenoid identification as per ISO 9461						
Wiring min. [mm <sup>2</sup> ]	3 x 1.5 recommended						
Wiring length max. [m]	50 recommended						

**Reduced pressure pA versus flow Q**  
**R4R03 <sup>1)</sup>**

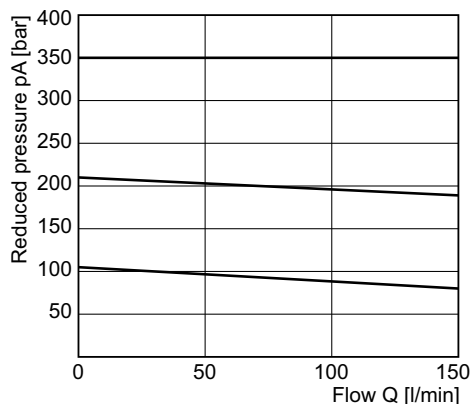

**Minimum pressure curve**

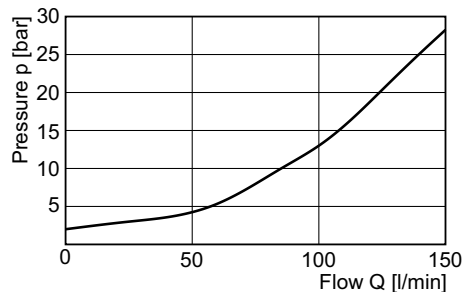

**Reduced pressure pA versus flow Q**  
**R4R06 <sup>1)</sup>**

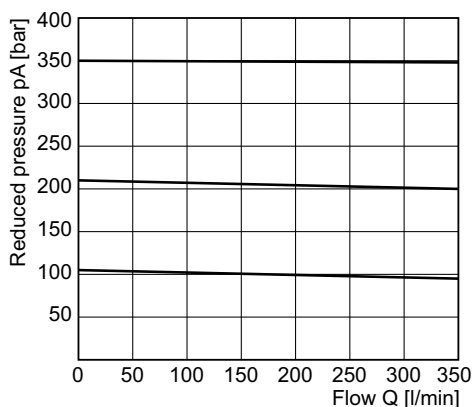

**Minimum pressure curve**

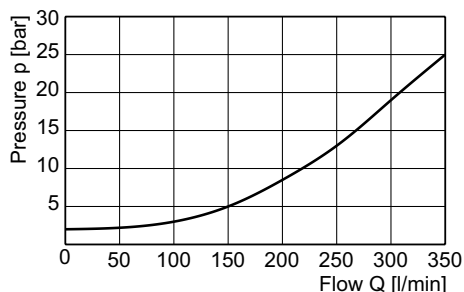

**Reduced pressure pA versus flow Q**  
**R4R10 <sup>1)</sup>**

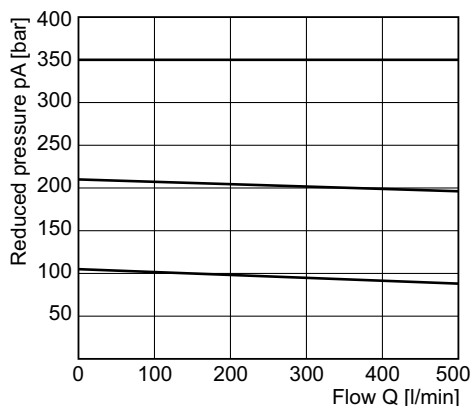

**Minimum pressure curve**

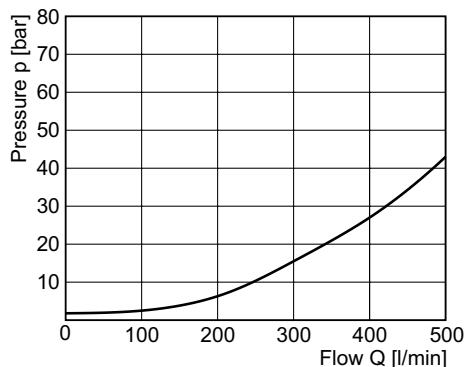

All characteristic curves measured with HLP46 at 50 °C.

<sup>1)</sup> Measured at 350 bar primary pressure pB.

**T-body**

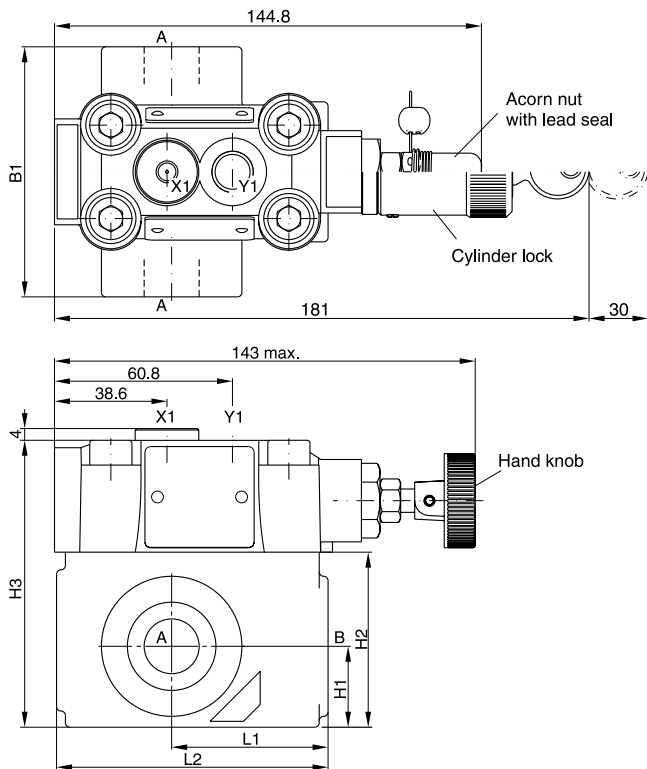

**L-body**

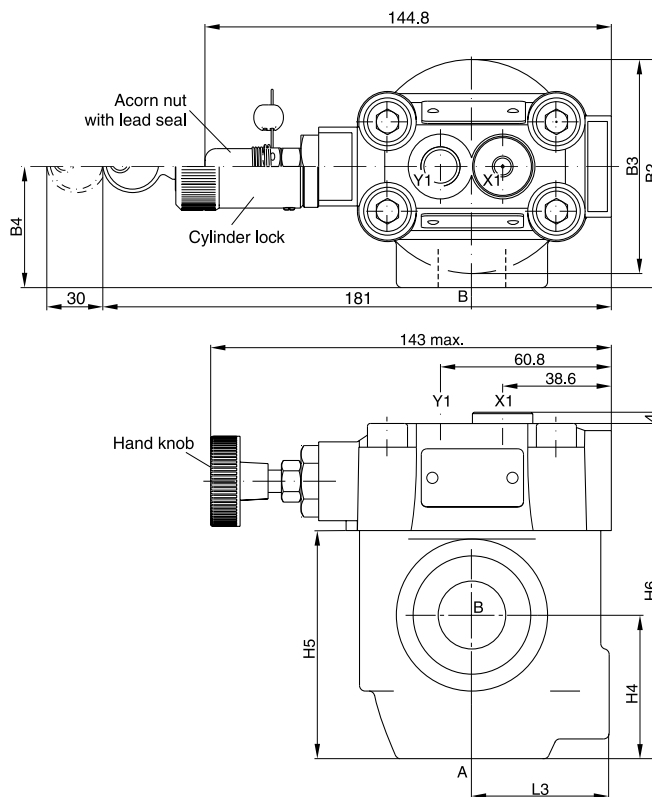

**10**

Seal kits		
NG	NBR	FPM
03	S26-58507-0	S26-58507-5
06	S26-58475-0	S26-58475-5
10	S26-58508-0	S26-58508-5

NG	Body	B1	B2	B3	B4	H1	H2	H3	H4	H5	H6	L1	L2	L3
03	T-body	85	-	-	-	27.5	59.5	97.5	-	-	-	53	92	-
06	T-body	136	-	-	-	38	93	131	-	-	-	66.5	117.5	-
06	L-body	-	81	76	43	-	-	-	51	81	119	-	-	49
10	L-body	-	120.7	85.8	77.8	-	-	-	50.8	96	134	-	-	49.8

Ports	Function	Port size			
		R4V03 T-body	R4V06 L-body	R4V06 T-body	R4V10 L-body
B	pressure (inlet)	G½ "	G¾ "	G1 "	G1¼ "
A	pressure (outlet)	G½ "	G¾ "	G1 "	G1¼ "
X1	external remote control or vent connection	G¼ "	G¼ "	G¼ "	G¼ "
Y1	external drain	G¼ "	G¼ "	G¼ "	G¼ "

**R4R with vent function**

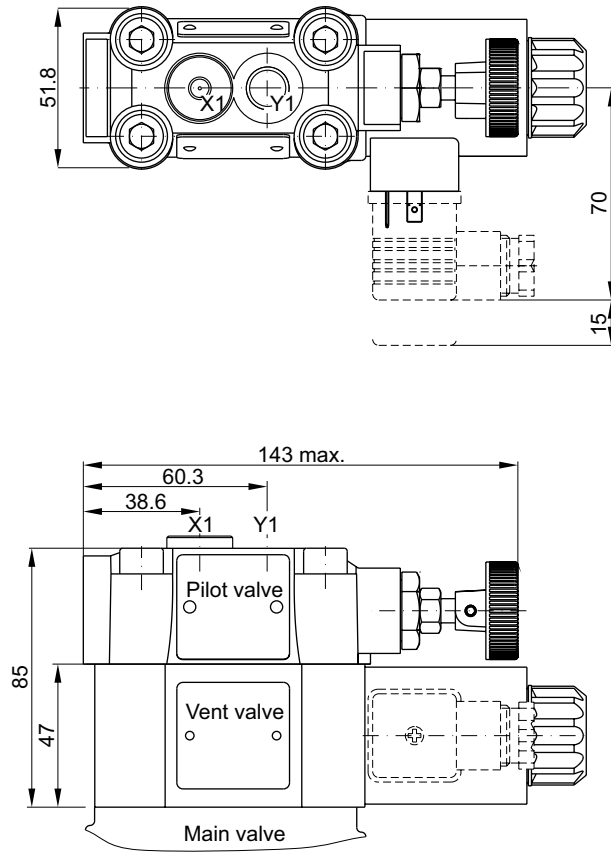

Seal kits	
NBR	FPM
<b>DC solenoid</b>	
S56-40609-0	S56-40609-5
<b>AC solenoid</b>	
S26-35237-0	S26-35237-5

Code	External drain
11	
09	